

# ----- **Parallel Installation Guide** -----

5.2KVA/6KVA/6.2KVA

## Table Of Contents

<b>1. Introduction.....</b>	<b>1</b>
<b>2. Package Contents.....</b>	<b>1</b>
<b>3. Mounting the Unit.....</b>	<b>1</b>
<b>4.Wiring Connection.....</b>	<b>1</b>
4-1. Parallel Operation in Single phase.....	3
4-2. Support 3-phase equipment .....	8
<b>5.PV Connection.....</b>	<b>8</b>
<b>6. LCD Setting and Display.....</b>	<b>9</b>
<b>7. Fault code display.....</b>	<b>9</b>
<b>8. Trouble shooting.....</b>	<b>10</b>

## 1. Introduction

This inverter can be used in parallel with two different operation modes.

1.Parallel operation in single phase is with up to 6 units. The supported maximum output power for 5.2KW is 31.2KW/31.2KVA. The supported maximum output power for 6KW is 36KW/36KVA.

2.Maximum 3 units work together to support three-phase equipment.

**WARNING:** Please make sure all output N wires of each inverter should be connected always. Otherwise, it will cause fault .

## 2.Package Contents

If the inverter is single model,please purchase parallel kit separately. In parallel kit, you will find the following items in the package:

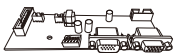

Parallel board



Parallel communication cable



Current sharing cable

## 3.Mounting the Unit

When installing multiple units, please follow below chart.

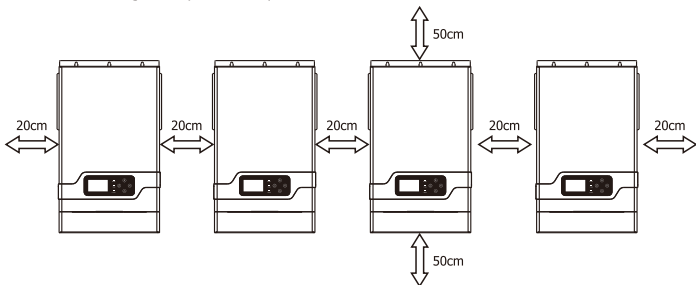

**NOTE:** For proper air circulation to dissipate heat, allow a clearance of approx. 20 cm to the side and approx. 50 cm above and below the unit. Be sure to install each unit in the same level.

## 4. Wiring Connection

**NOTICE:** It's required to connect to battery for parallel operation.

The cable size of each inverter is shown as below:

## Recommended battery cable and terminal size for each inverter:

Model	Wire Size	Cable mm <sup>2</sup> (each)	Ring Terminal Dimensions		Torque Value
			D(mm)	L(mm)	
			5.2KW/6KW/6.2KW	1*2AWG	
	2*4AWG	25	6.4	33.2	

Ring terminal:

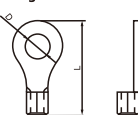

**WARNING:** Be sure the length of all battery cables is the same. Otherwise, there will be voltage difference between inverter and battery to cause parallel inverters not working.

## Recommended AC input and output cable size for each inverter:

AWG no.	Torque
10 AWG	1.2~ 1.6Nm

You need to connect the cables of each inverter together. Take the battery cables for example: You need to use a connector or bus-bar as a joint to connect the battery cables together, and then connect to the battery terminal. The cable size used from joint to battery should be X times cable size in the tables above. "X" indicates the number of inverters connected in parallel. Regarding AC input and output, please also follow the same principle.

**CAUTION!!** Please install the breaker at the battery and AC input side. This will ensure the inverter can be securely disconnected during maintenance and fully protected from over current of battery or AC input. The recommended mounted location of the breakers is shown in the figures in 4-1 and 4-2.

## Recommended breaker specification of battery for each inverter:

<b>1 unit*</b>
140A/70VDC

\*If you want to use only one breaker at the battery side for the whole system, the rating of the breaker should be X times current of 1 unit. "X" indicates the number of inverters connected in parallel.

## Recommended breaker specification of AC input with single phase:

2 units	3 units	4 units	5 units	6 units
80A/230VAC	120A/230VAC	160A/230VAC	200A/230VAC	240A/230VAC

**Note1:** Also, you can use 50A breaker for only 1 unit and install one breaker at its AC input in each inverter.

**Note2:** Regarding three-phase system, you can use 4-pole breaker directly and the rating of the breaker should be compatible with the phase current limitation from the phase with maximum units

## Recommended battery capacity:

Inverter parallel numbers	2	3	4	5	6
Battery Capacity	200AH	400AH	400AH	600AH	600AH

**WARNING!** Be sure that all inverters will share the same battery bank. Otherwise, the inverters will transfer to fault mode.

#### 4-1.Parallel Operation in Single phase

Two inverters in parallel:  
**Power Connection**

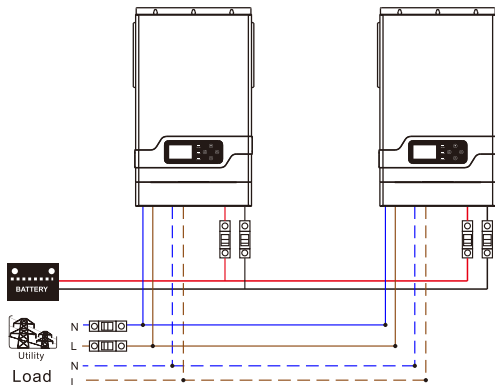

#### Communication Connection

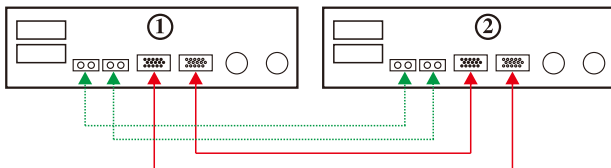

Before setting the machine address, disconnect the inverter outputs from each other and the inputs from each other.

Inverter ① set option 42 to 1P1 and restart the inverter to check whether the setting is successful.

Inverter ② set option 42 to 1P2 and restart the inverter to check whether the setting is successful.

## Three inverters in parallel:

### Power Connection

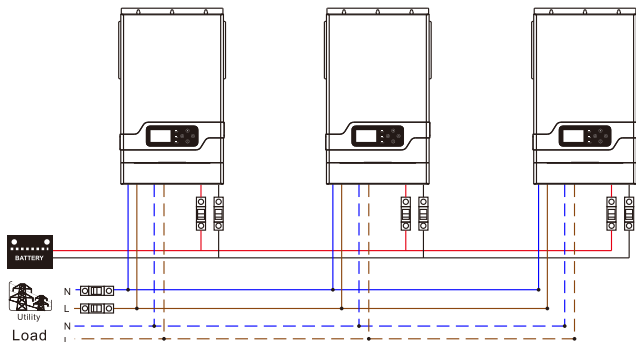

### Communication Connection

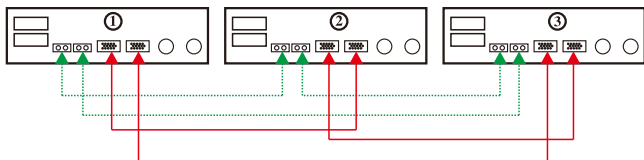

Before setting the machine address, disconnect the inverter outputs from each other and the inputs from each other.

Inverter ① set option 42 to 1P1 and restart the inverter to check whether the setting is successful.

Inverter ② set option 42 to 1P2 and restart the inverter to check whether the setting is successful.

Inverter ③ set option 42 to 1P3 and restart the inverter to check whether the setting is successful.

Four inverters in parallel:

## Power Connection

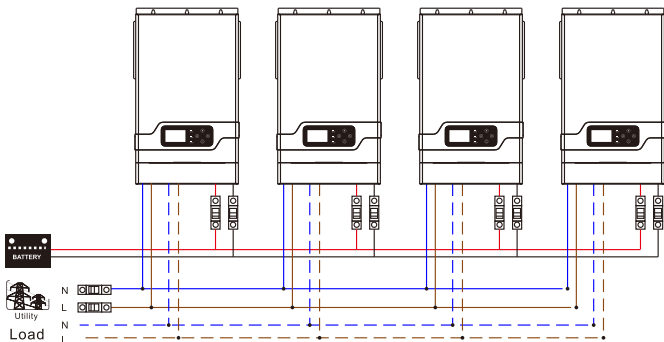

## Communication Connection

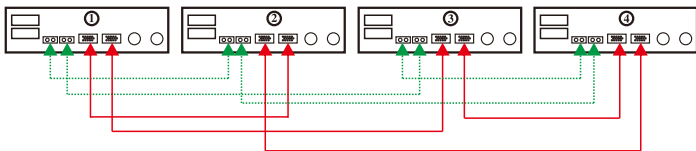

Before setting the machine address, disconnect the inverter outputs from each other and the inputs from each other.

Inverter ① set option 42 to 1P1 and restart the inverter to check whether the setting is successful.

Inverter ② set option 42 to 1P2 and restart the inverter to check whether the setting is successful.

Inverter ③ set option 42 to 1P3 and restart the inverter to check whether the setting is successful.

Inverter ④ set option 42 to 1P4 and restart the inverter to check whether the setting is successful.

## Four inverters in parallel: Power Connection

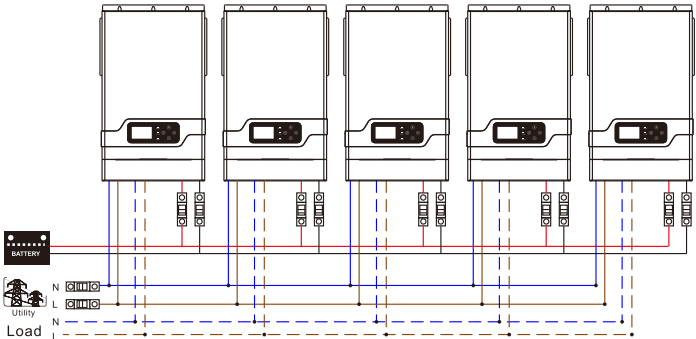

## Communication Connection

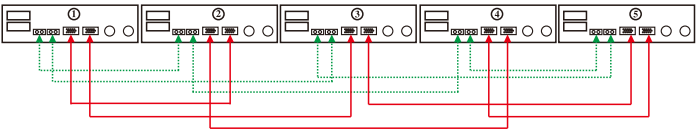

Before setting the machine address, disconnect the inverter outputs from each other and the inputs from each other.

Inverter ① set option 42 to 1P1 and restart the inverter to check whether the setting is successful.

Inverter ② set option 42 to 1P2 and restart the inverter to check whether the setting is successful.

Inverter ③ set option 42 to 1P3 and restart the inverter to check whether the setting is successful.

Inverter ④ set option 42 to 1P4 and restart the inverter to check whether the setting is successful.

Inverter ⑤ set option 42 to 1P5 and restart the inverter to check whether the setting is successful.

## Six inverters in parallel: Power Connection

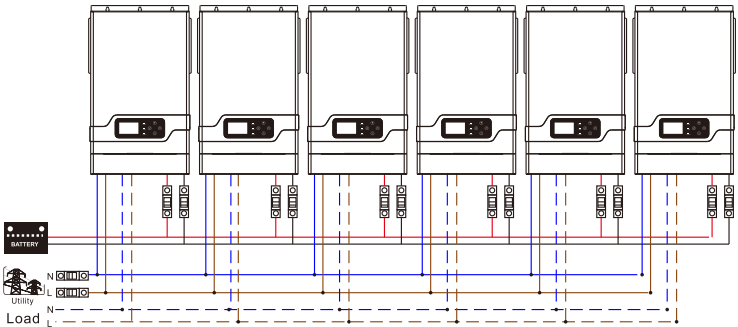

## Communication Connection

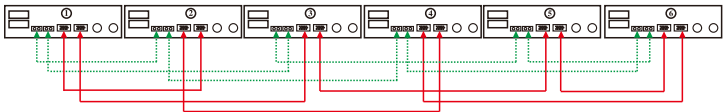

Before setting the machine address, disconnect the inverter outputs from each other and the inputs from each other.

Inverter ① set option 42 to 1P1 and restart the inverter to check whether the setting is successful.

Inverter ② set option 42 to 1P2 and restart the inverter to check whether the setting is successful.

Inverter ③ set option 42 to 1P3 and restart the inverter to check whether the setting is successful.

Inverter ④ set option 42 to 1P4 and restart the inverter to check whether the setting is successful.

Inverter ⑤ set option 42 to 1P5 and restart the inverter to check whether the setting is successful.

Inverter ⑥ set option 42 to 1P6 and restart the inverter to check whether the setting is successful.

## 4-2. Support 3-phase equipment

One inverter in each phase:

### Power Connection

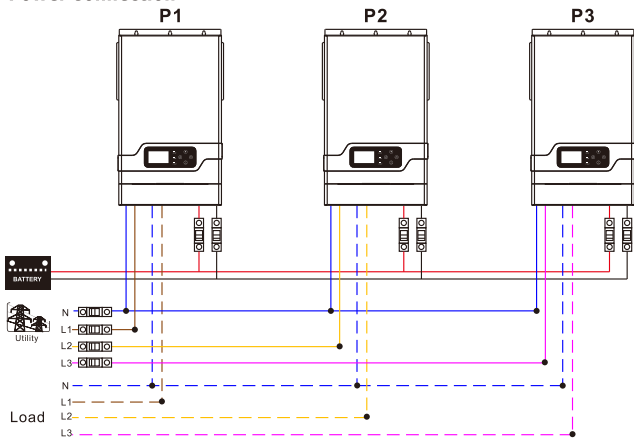

### Communication Connection

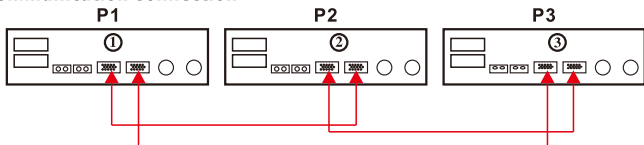

Before setting the machine address, disconnect the inverter outputs from each other and the inputs from each other.

Inverter ① set option 42 to 3A1 and restart the inverter to check whether the setting is successful.

Inverter ② set option 42 to 3B1 and restart the inverter to check whether the setting is successful.

Inverter ③ set option 42 to 3C1 and restart the inverter to check whether the setting is successful.

**WARNING:** Do not connect the current sharing cable between the inverters which are in different phases. Otherwise, it may damage the inverters.

## 5.PV Connection

Please refer to user manual of single unit for PV Connection.











CAUTION: Each inverter should connect to PV modules separately

## 6.LCD Setting and Display

### Setting Program

42	Parallel address Setting (After the program is set, please restart the inverter to take effect.Before confirming that the settings are in effect ,please disconnect the connection between the machine outputs)	Single: This inverter is used in single phase application	Parallel: This inverter is operated in parallel system (you can set the first machine to 1P1, the second machine to 1P2, the third machine to 1P3, and so on)
		When the inverter is operated in 3-phase application, set up inverter to be operated in specific phase	
		A phase: (you can set the first machine in phase A to 3A1)	B phase: (you can set the first machine in phase B to 3B1)
		C phase: (you can set the first machine in phase C to 3C1)	

### 7. Fault code display:

Fault Code	Fault Event	Icon on
80	CAN fault	
81	Host loss	
82	Synchronization loss	
83	Battery voltage detected different	
84	AC input voltage and frequency detected different	
85	AC output current unbalance	
86	AC output mode setting is different	
87	Power feedback protection	
88	Firmware version inconsistent	
89	Current sharing fault	
90	CAN ID setting Error	

## 8. Trouble shooting

Situation		Solution
Fault Code	Fault Event Description	
80	CAN data loss	1.Check if communication cables are connected well and restart the inverter. 2.If the problem remains, please contact your installer.
81	Host data loss	
82	Synchronization data loss	
83	The battery voltage of each inverter is not the same.	1.Make sure all inverters share same groups of batteries together. 2.If the problem remains, please contact your installer.
84	AC input voltage and frequency are detected different	1.Check the utility wiring connection and restart the inverter. 2.If the problem remains, please contact your installer.
85	AC output current unbalance	1.Restart the inverter. 2.If the problem remains, please contact your installer
86	AC output mode setting is different	1.Switch off the inverter and check the DIP switch setting. 2.If the problem remains, please contact your installer.
87	Current feedback into the inverter is detected.	1.Restart the inverter. 2.If the problem remains, please contact your installer.
88	The firmware version of each inverter is not the same.	1.Update all inverter firmware to the same version. 2.If the problem remains, please contact your installer.
89	The output current of each inverter is different.	1.Check if communication cables are connected well and restart the inverter. 2.If the problem remains, please contact your installer.
90	CAN ID setting Error	1.Switch off the inverter and check the DIP switch setting. 2.If the problem remains, please contact your installer.

## CONEXION SEIS INVERSORES EN PARALELO

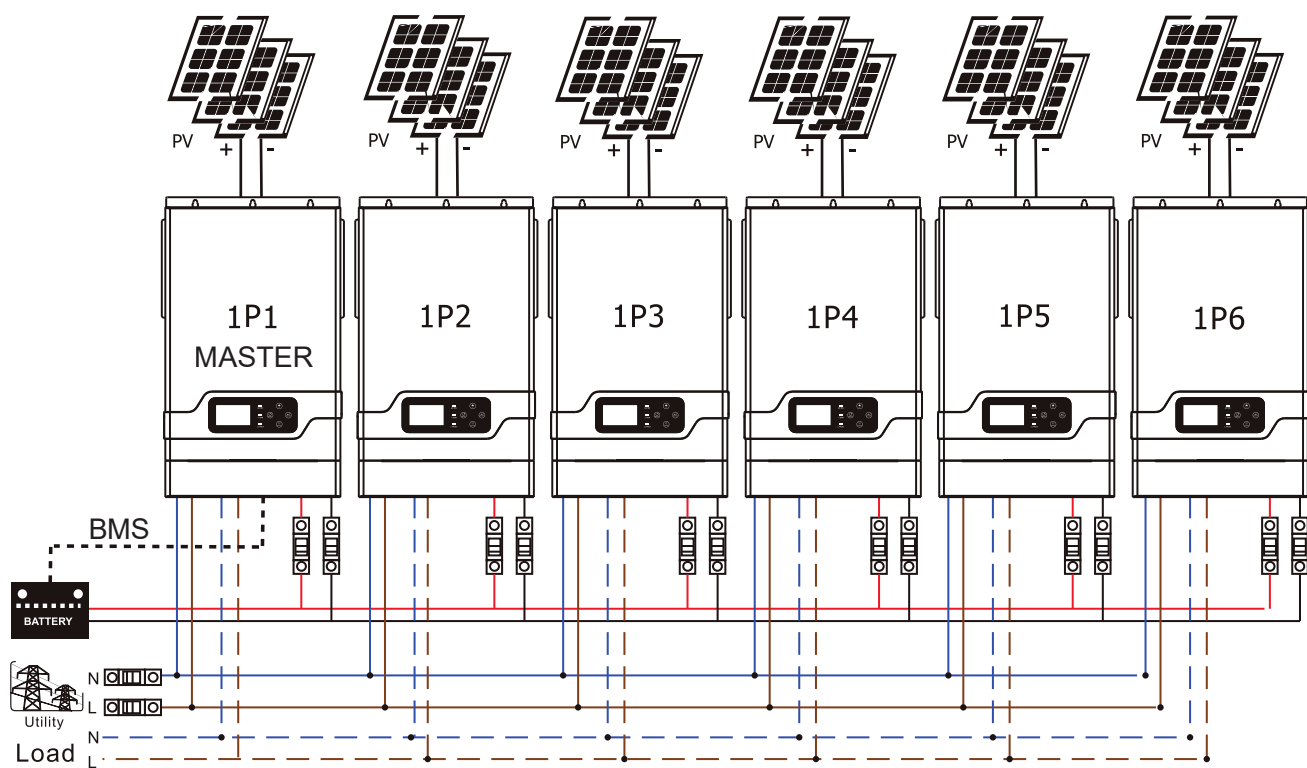

### Communication Connection

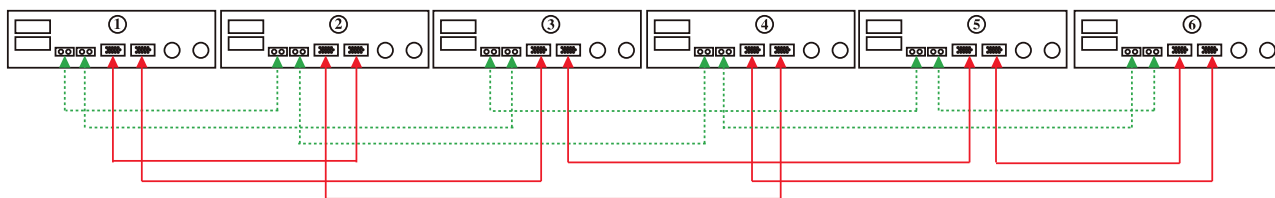

## CONEXION TRIFÁSICA - 1 INVERSOR POR FASE

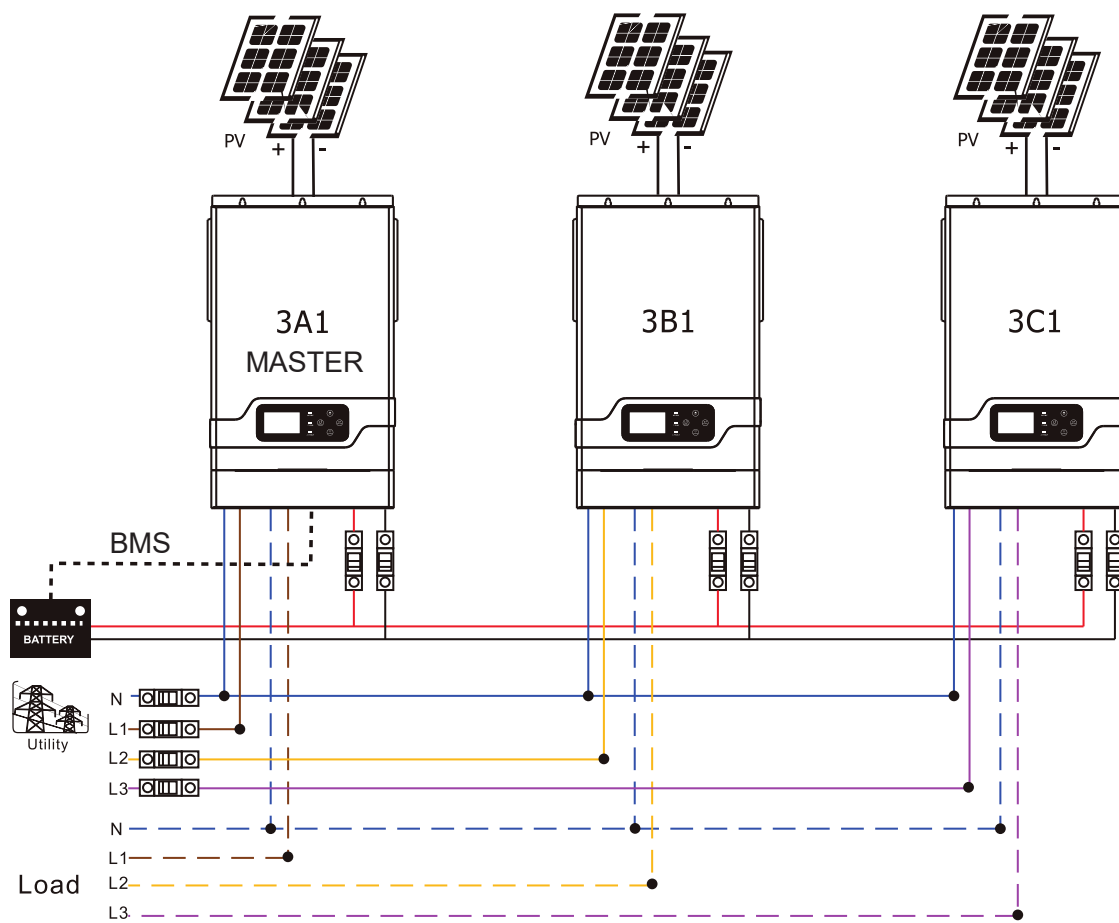

### Communication Connection

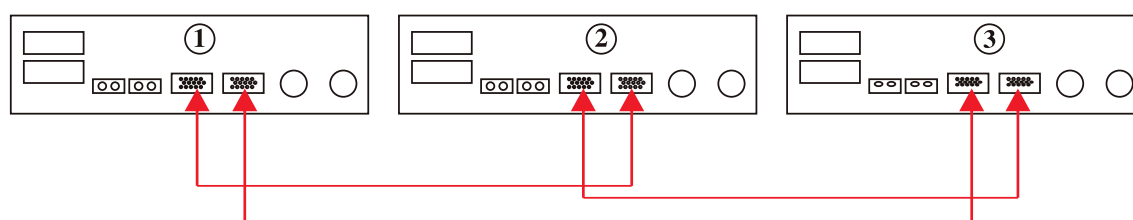

La programación del BMS, en ambos modos de conexión, se realiza en el MASTER, luego este la comunica a los otros inversores